

Eclipse RatioMatic

Burners

Model RM3000

Version 5

Parameter	Specification	
Blower Type	Chamber Pressure "w.c. (mbar)	60 Hz Packaged Blower
Maximum Input, Btu/h (kW)¹ <i>Contact factory for varying chamber pressures or pressures outside the range or varying chamber pressure conditions.</i>	-5.0 (-12.5)	32,200,000 (9428)
	-3.0 (-7.5)	32,000,000 (9370)
	-1.0 (-2.5)	30,700,000 (8989)
	0.0 (0.0)	30,000,000 (8784)
	1.0 (2.5)	29,300,000 (8579)
	2.0 (5.0)	28,600,000 (8374)
Minimum Input On-Ratio, Btu/h (kW)²	1,500,000 (439)	
Maximum Chamber Temperature °F (°C)	Burner with alloy tube	1500°F (815°C)
	Burner with refractory block	1900°F (1038°C)
Main Gas Inlet Pressure, "w.c. (mbar)³ <i>Fuel pressure at ratio regulator inlet</i>	38 to 55 (95 to 138)	
Pilot Gas Pressure at the Pilot Cock Inlet	Minimum: 6" w.c. (15 mbar)	
High Fire Flame Length, inches (mm) <i>Measured from the outlet end of the combustor</i>	200" (5.08 m) Measured from the end of the firing tube	
Pilot	Integral spark-ignited pilot	
Flame Detection	UV scanner only.	
Fuels⁴ <i>For any other mixed gas, contact Eclipse, Inc.</i>	Standard nozzles burn natural gas, propane, propane/air mixes without changing internals.	
Blower Motor Power, Hp	40.0	
Weights, lbs (kg)⁵	Alloy Tube	1157 (525)
	Refractory	1627 (738)
Approvals		

¹ Maximum inputs for packaged blower versions are given for the standard combustion air blower without an inlet air filter.

² Turndown input based on neutral chamber conditions. Contact Eclipse for other chamber pressures.

³ For proper performance, this pressure must be kept constant across the burner operating range.

⁴ See Design Guide 110 for more information about typical fuel composition and properties.

⁵ All weights are approximate.

- All information is based on laboratory testing. Different chamber conditions will affect the data.
- All inputs based upon gross calorific values and standard conditions; 1 atmosphere, 70°F (21°C).
- Eclipse reserves the right to change the construction and/or configuration of our products at any time without being obliged to adjust earlier supplies accordingly.

Performance Graphs

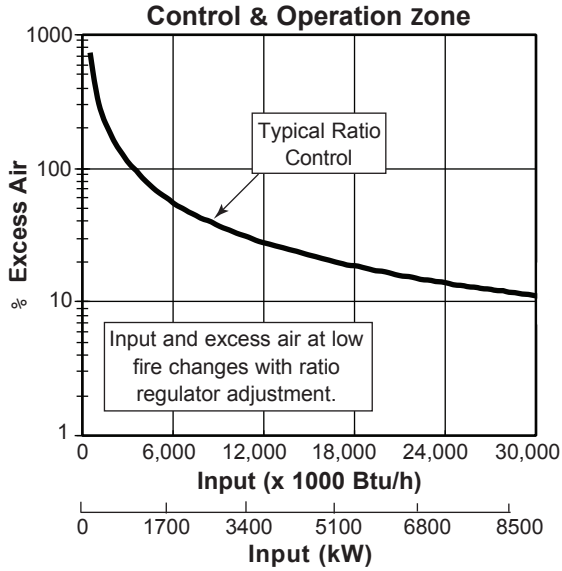

Emissions are influenced by:

- Chamber conditions
- Fuel type
- Firing rate
- Ratio regulator adjustment
- Combustion air temperature

CO emission is largely influenced by chamber conditions. Contact your local Eclipse representative for an estimate of CO emission on your application.

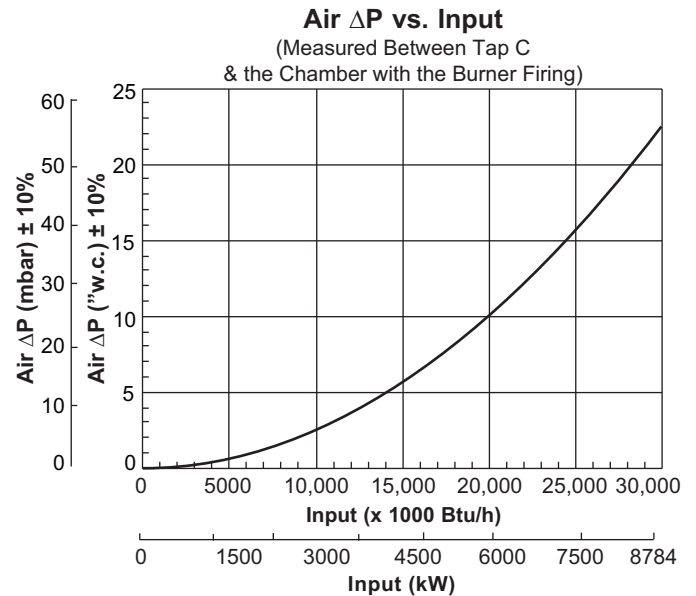
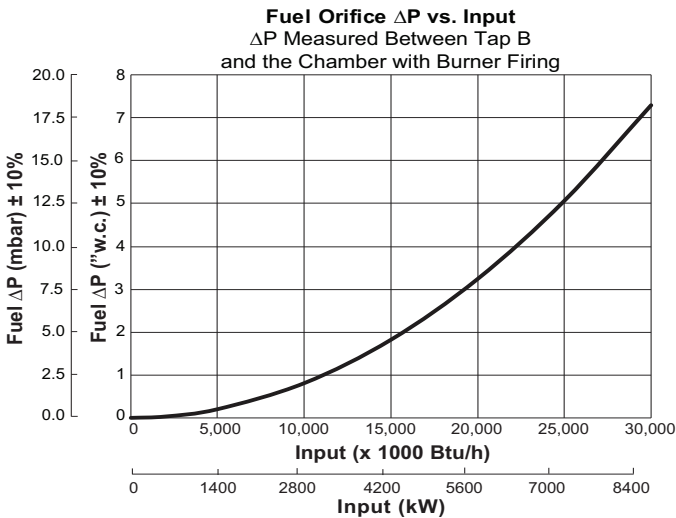

Dimensions and Specifications

Dimensions in mm (in)

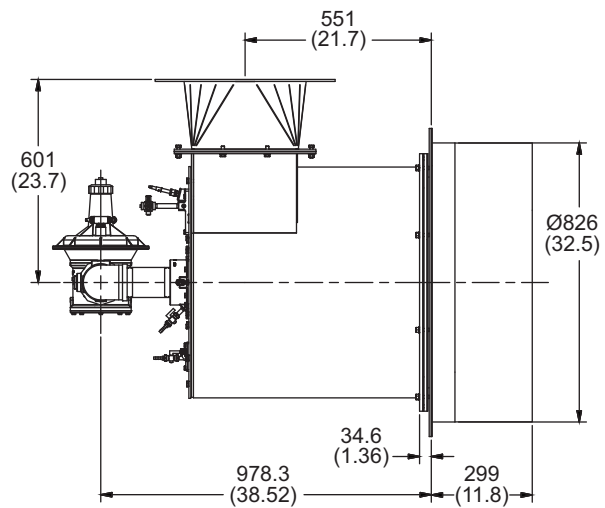
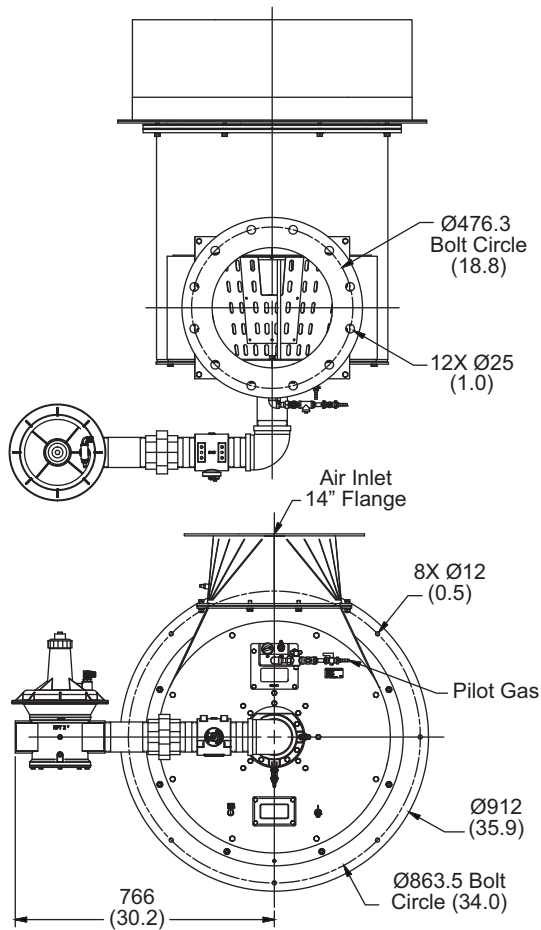
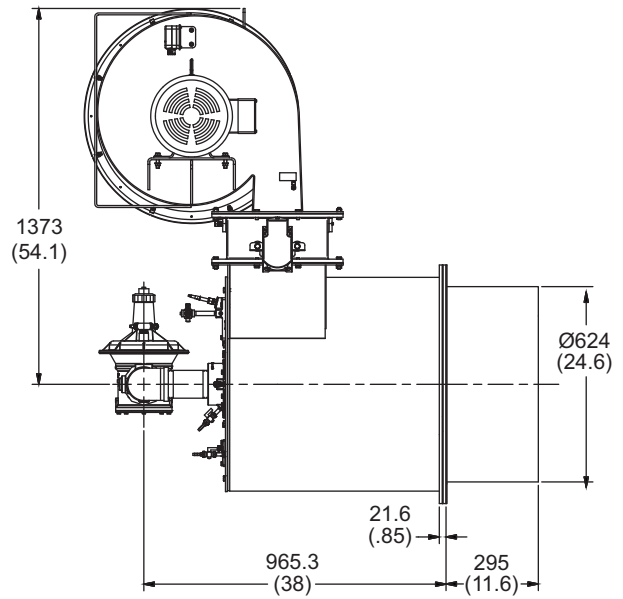
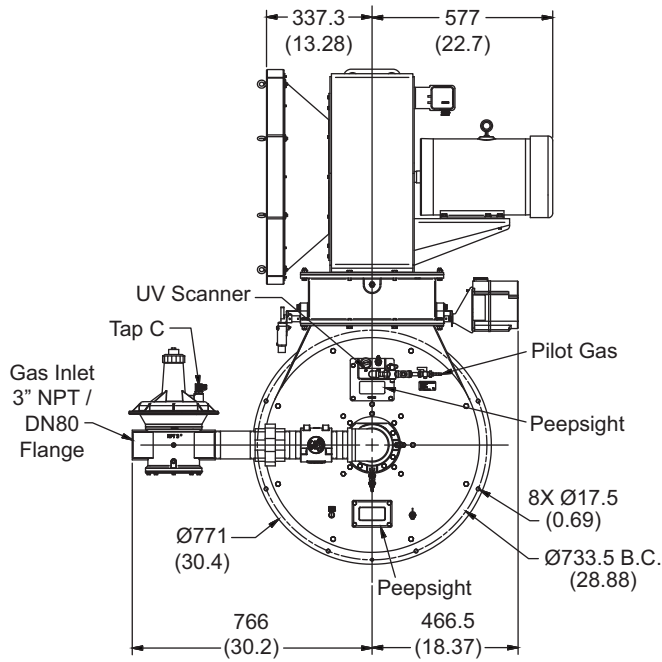

Shown with Block and Holder

Burner Configuration

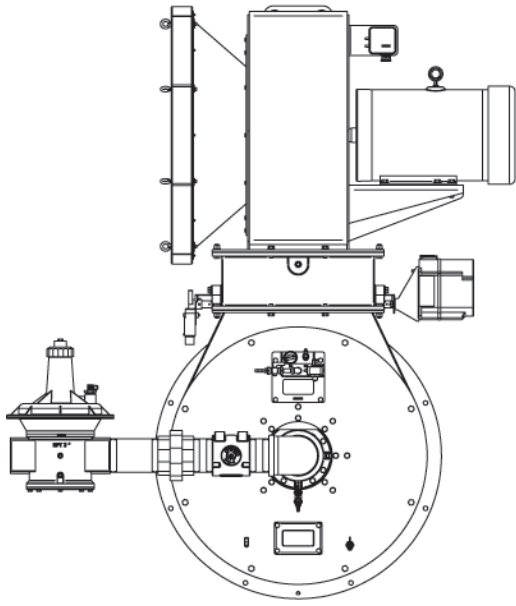

Burner Hand Piping

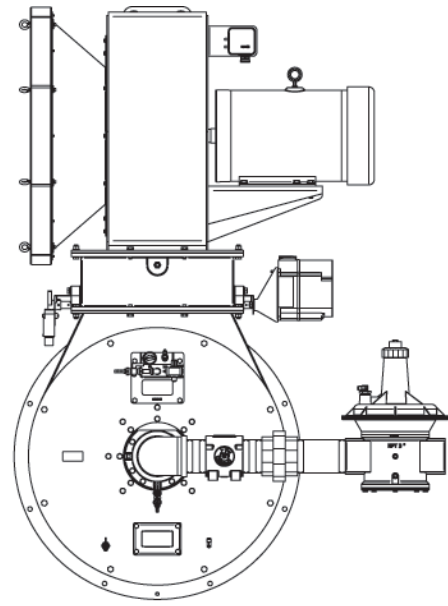

Right Hand Piping